

IT Recruitment & Retention Report

AUTUMN 2008

beddison

Introduction from our MD

Firstly, thank you to all those organisations who contributed information to the report.

The findings of this year's survey confirm that strong demand for IT staff is likely to continue in 2008. There are also some interesting findings around the approach to recruitment that show how many organisations are adapting to the circumstances, and highlight where opportunities to attract the best staff still exist.

I look forward to Clicks continuing its relationship with you over the year. Please feel free to contact me at any time if you want an update, or if you need our support with your recruitment activity.

Best wishes



Ben Wood
Managing Director
Level 21, 303 Collins Street
Melbourne VIC 3000
T: 03 9963 4884
F: 03 9963 4880
E: benw@clicksrecruit.com.au
W: www.clicksrecruit.com.au



1. Key Findings

During December 2007 we received around 200 responses to our electronic survey sent to organisations across a range of industries in Sydney, Melbourne and Canberra.

This is the 9th edition of our IT Recruitment and Retention Report. Data is compared to that gained 12 months ago and is analysed by organisation size and industry sector.

In summary the data reveals:

- A very positive business environment with 61% of organisations expecting an increase in sales turnover.
- 41% of organisations expect to increase their IT budget over the next 12 months; however the number expecting to decrease has doubled to 11% compared with 12 months ago.
- 41% (compared with 35% 12 months ago) of organisations plan to increase their numbers of IT staff, with 40% planning to hire more permanent staff and 29% planning to use more contractors.
- Average salary increases are set to average 4.6% over the next 12 months.
- 57% (compared with 45% 12 months ago) of respondents report that they have paid more than anticipated to hire IT staff.
- Staff turnover levels have increased with 45% of organisations reporting turnover of 5% or less (compared with 62% 12 months ago) and 20% reported turnover of 15%+ (compared with 11% 12 months ago)
- A rapid increase in the amount of IT graduate recruitment with 37% (compared with 27% 12 months ago) of organisations hiring an IT graduate in 2007.
- IT workers are working longer hours, with those working more than 40 hours a week increasing from 38% to 44%.

2. Business Environment

2.1 Sales Turnover

Overall the business environment remains very positive, with similar sentiments expressed when compared to 12 months ago, with 61% expecting sales to increase in 2008. In fact, the number of respondents expecting sales growth of more than 20% has increased from 12% to 14%.

2.1.1 Over the next 12 months, how do you expect your sales (\$ turnover) to change?

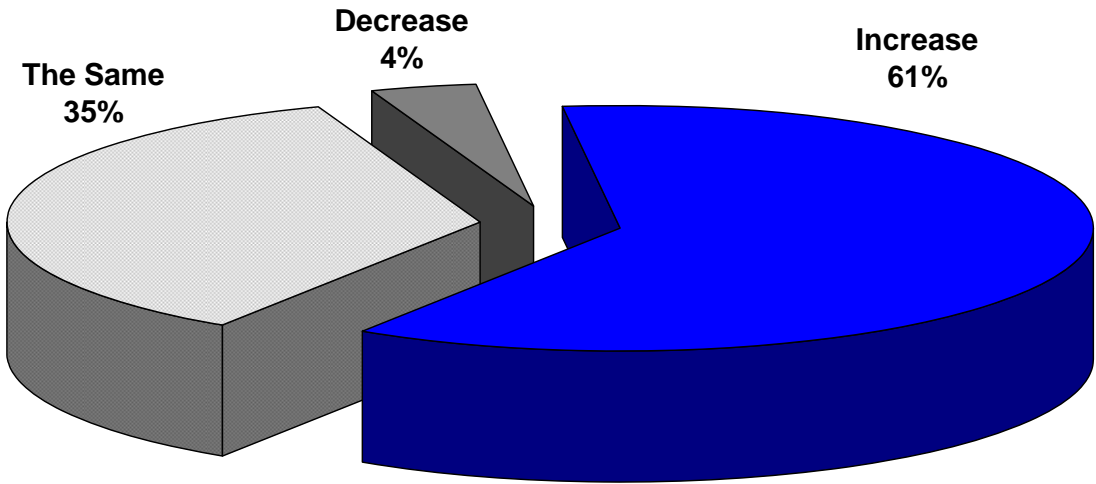

2.1.2 If you expect an increase, by what percentage? (by Industry sector)

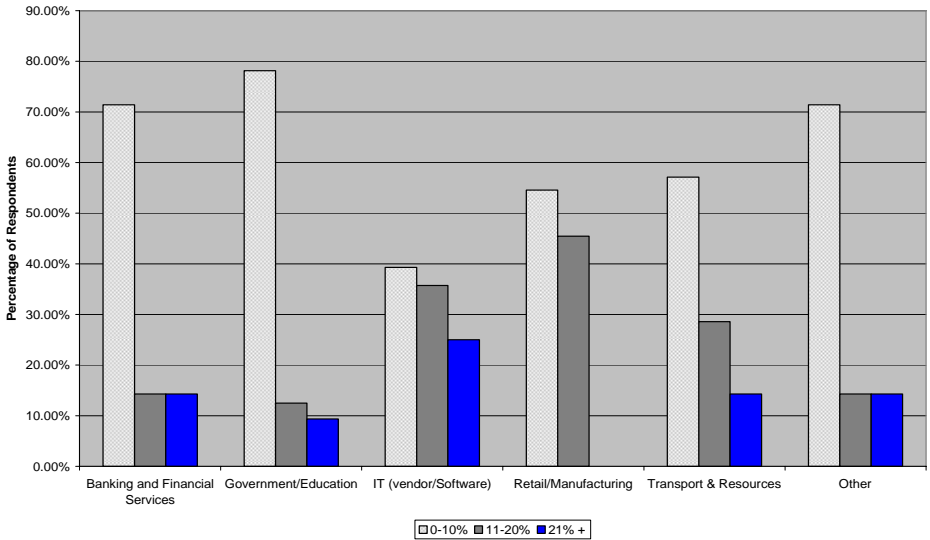

2.2 IT Budget

Whilst similar to 12 months ago, there are stronger indications that spend on IT will tighten over the next 12 months. Whilst 41% expect their budget to increase, the number of respondents who anticipated their budget will decrease has doubled to 11%. The Banking and Financial Services sector has the lowest level of 'No Change' response. Of those increasing their IT budget, many cite business growth resulting in the need for additional staff and locations as well as changes in infrastructure and upgrading of equipment, as reasons.

2.2.1 Change in IT budget over the next 12 months

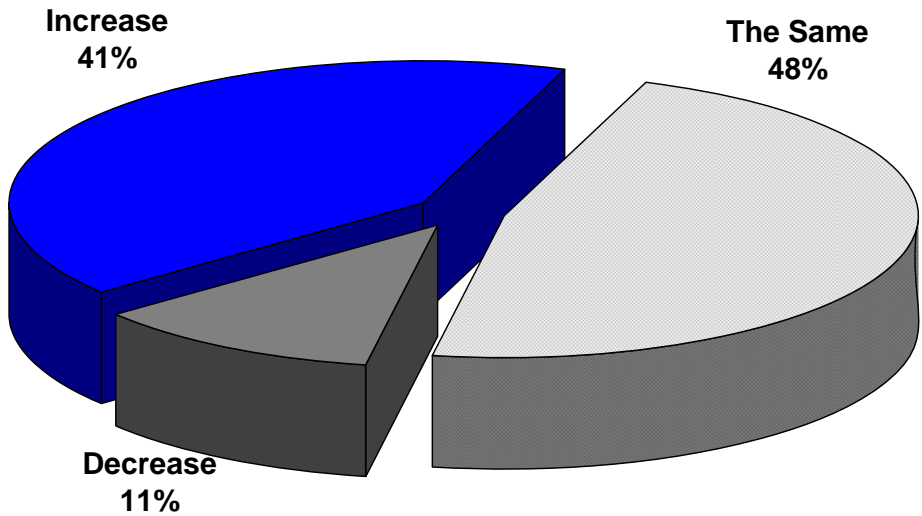

2.2.2 Change in IT budget by Industry sector

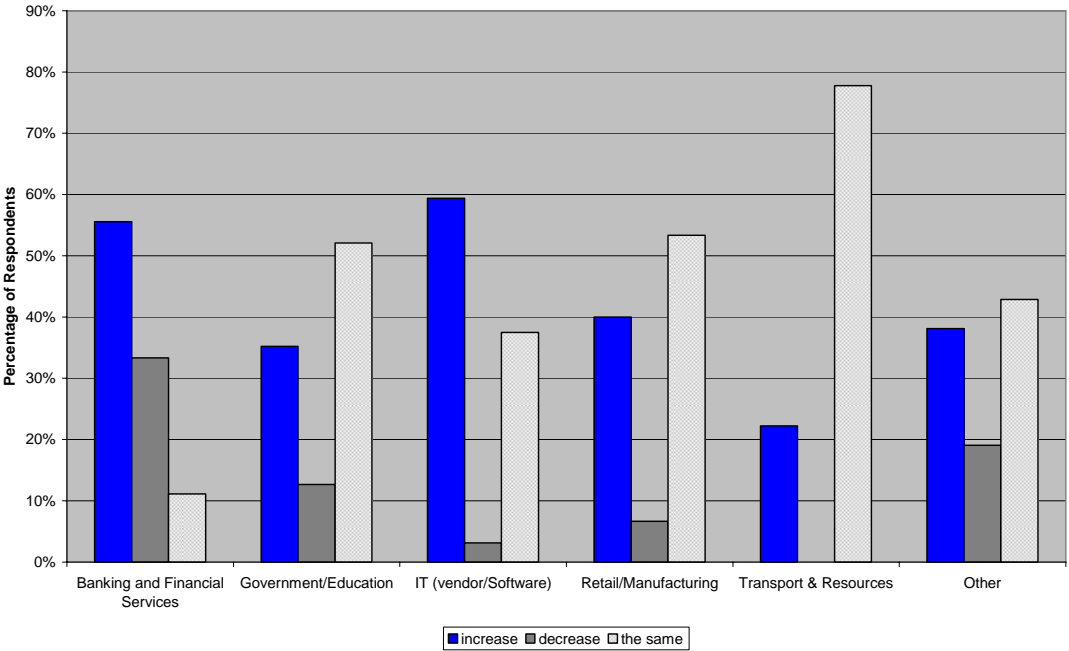

3. Staffing Levels: 'Hiring or Firing?'

There has been a sharp increase in the number of respondents anticipating an increase of IT staff numbers from 34% 12 months ago to 41%. There has also been a threefold increase in those expecting to increase staff numbers by more than 20%. 94% of respondents expect to use IT contractors and 40% expect to increase their number of permanent IT staff, both up compared to 12 months ago. Government, as an industry sector, is most likely to use more contractors.

3.1 Survey respondents by Number of IT Staff

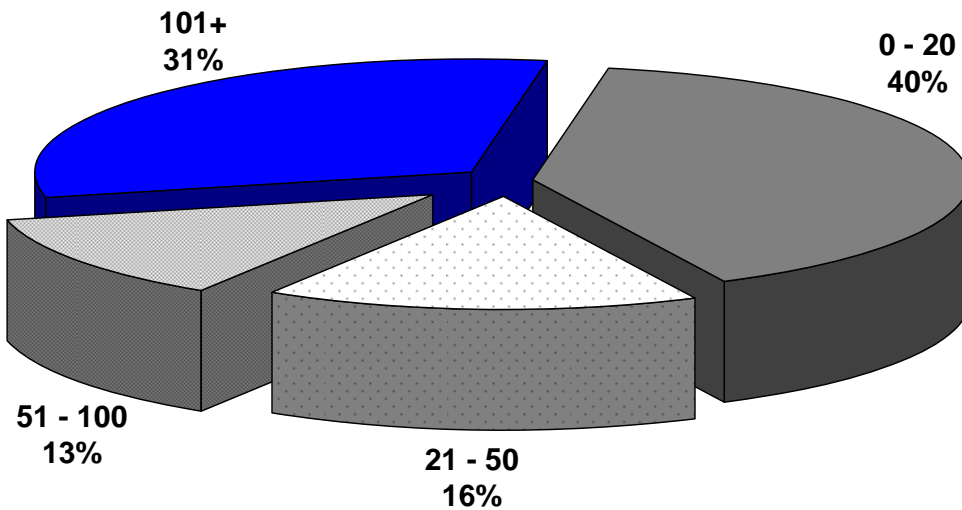

3.2 Over the next 12 months, how do you expect your total IT staff numbers to change?

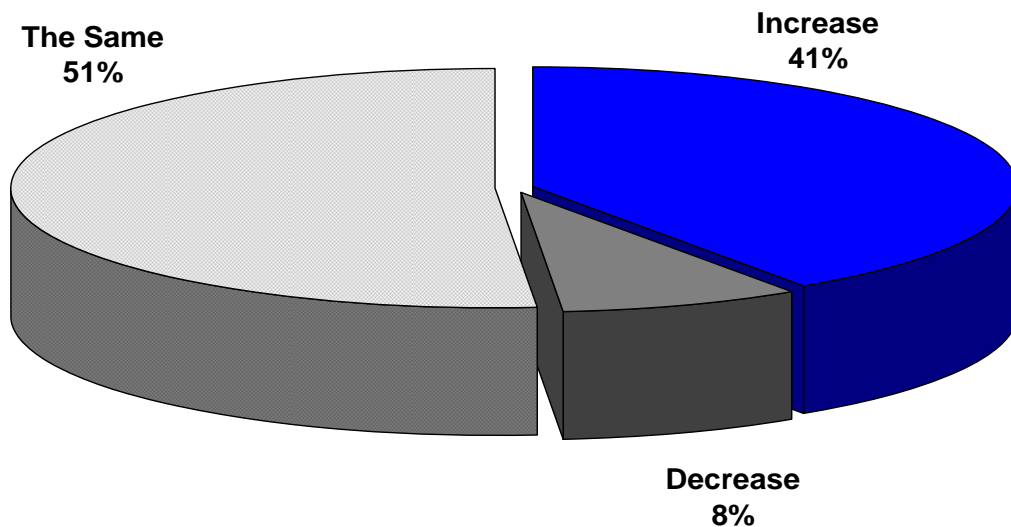

3.3 If increasing, by what percentage?

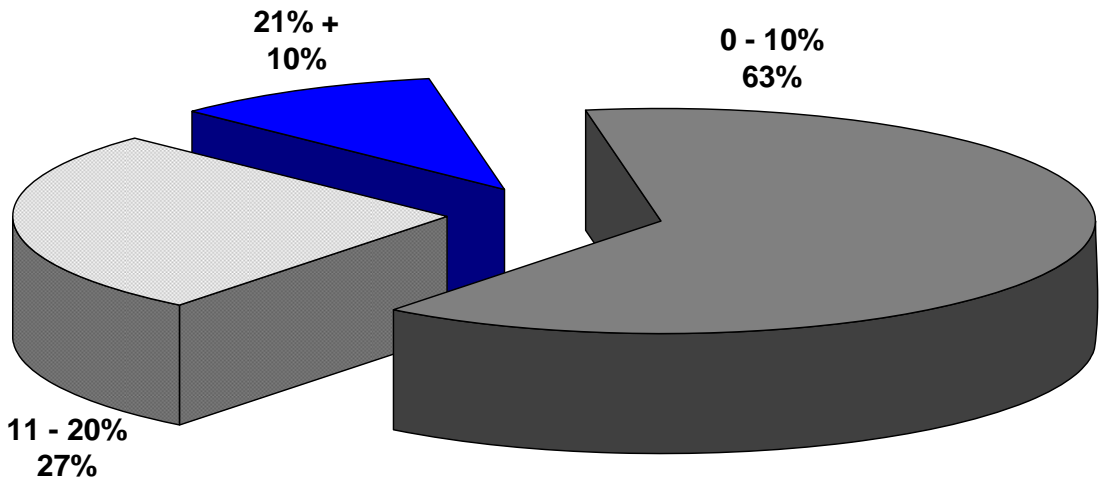

3.4 Do you expect to increase the number of your permanent IT staff over the next 12 months?

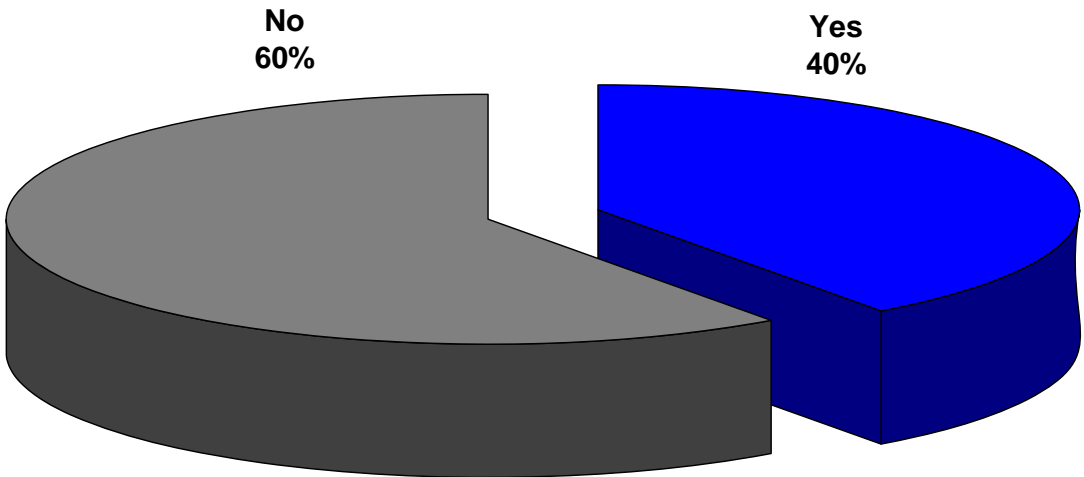

3.5 Over the next 12 months, do you expect your usage of IT Contractors will be greater or less than over the last 12 months?

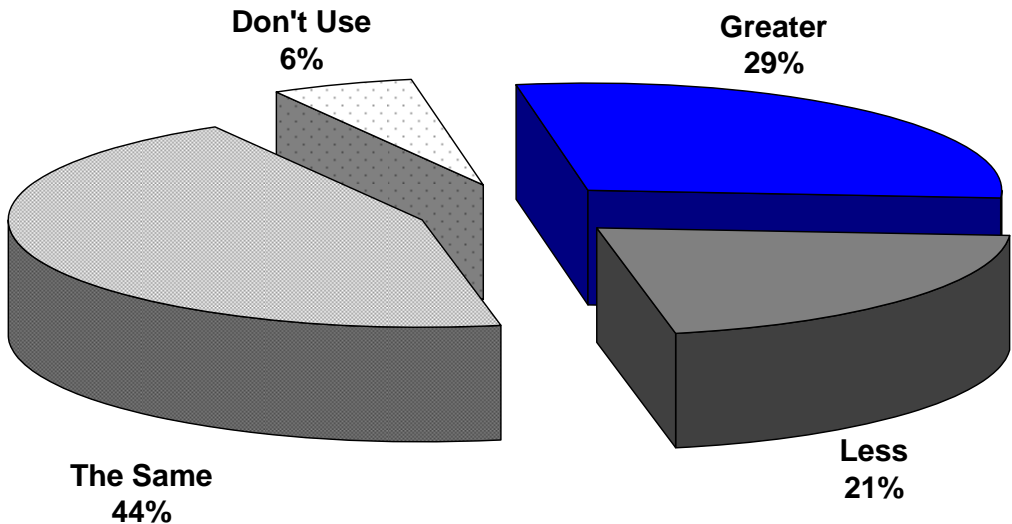

3.6 Over the next 12 months, do you expect your usage of IT Contractors will be greater or less than over the last 12 months? (by Industry sector)

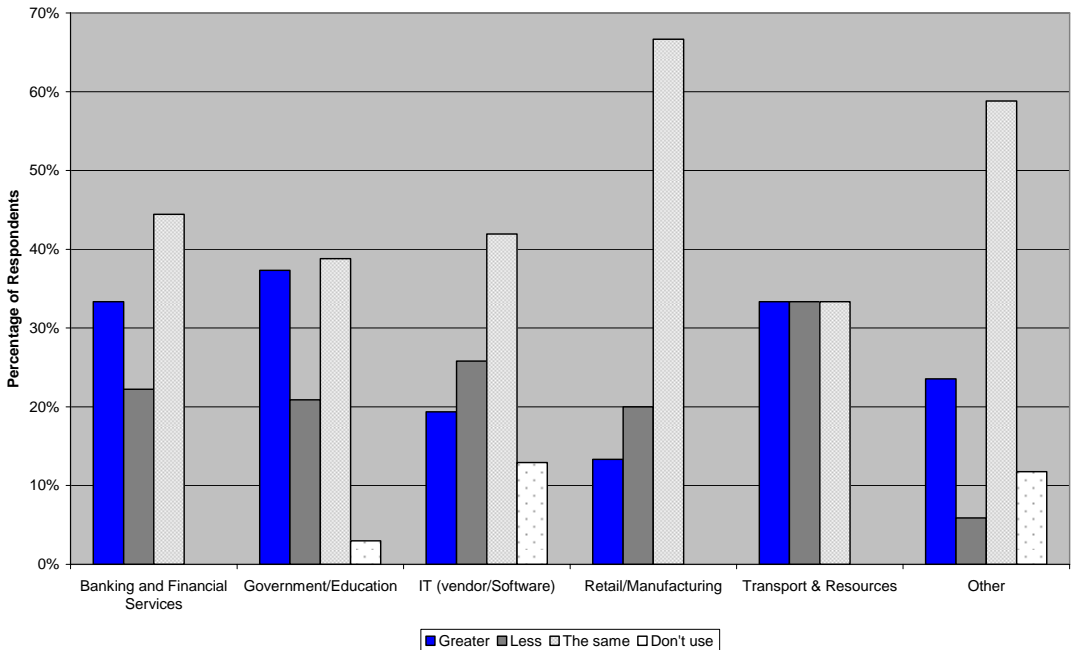

4. 'Show Us The Money'

4.1 Comparison of 2007 expected IT salary increase rate compared with actual, and 2008 expectations

The level of salary increase is well controlled. Twelve months ago the average increase expected in 2007 was 4.5%. However the actual increase was 4.2%. The average expected increase in 2008 is 4.6%

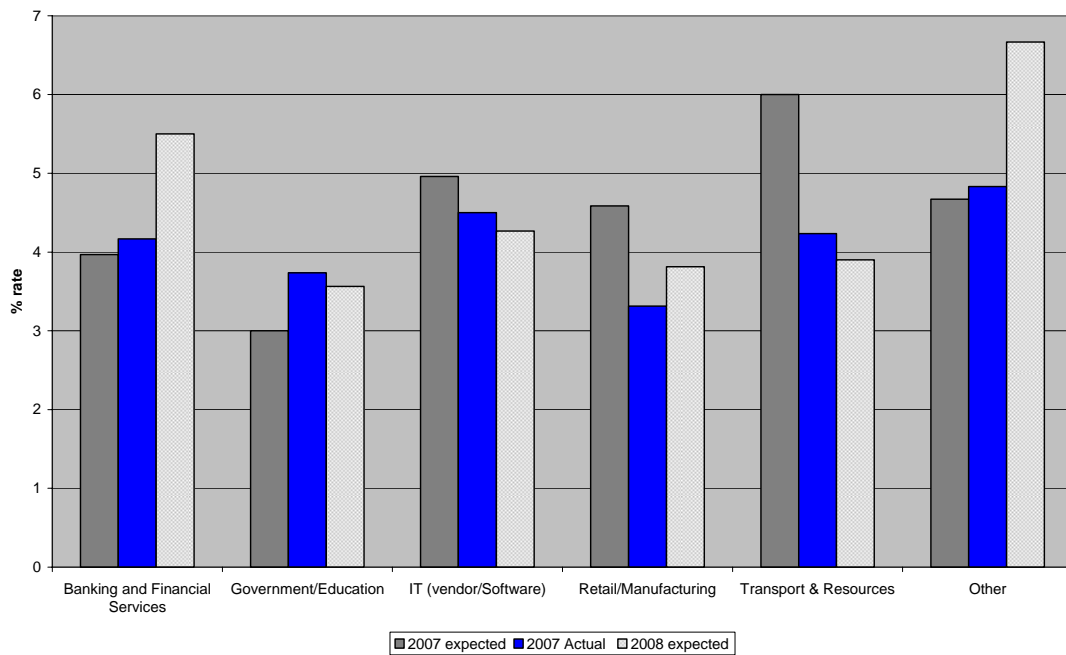

4.2 Over the last year, have you had to counteroffer an IT employee who had resigned, in order to retain their services?

29% of respondents have had to counteroffer an employee in the last 12 months. This is up from 17% 12 months ago, and is a clear indication that managers are recognising that the pain of rehiring is increasing

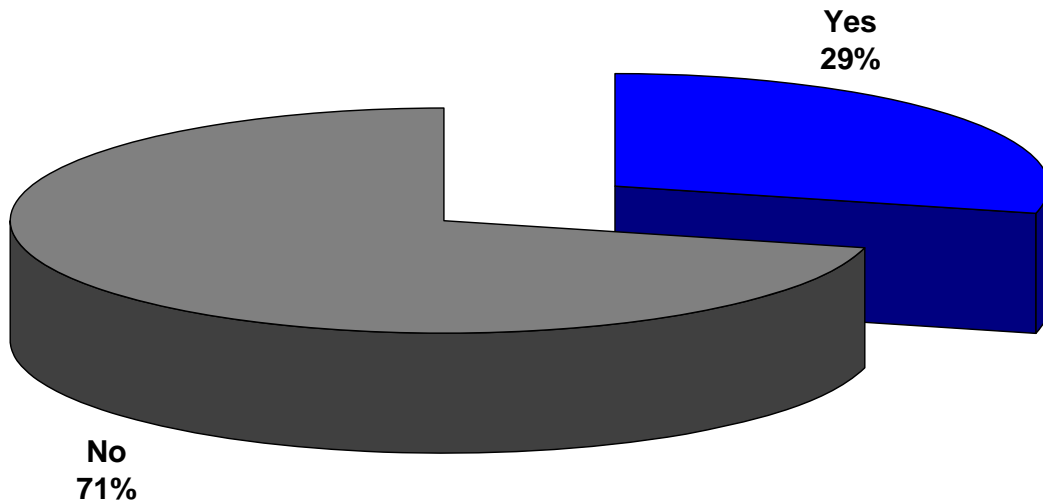

4.3 When recruiting IT staff in the last year, have you had to pay more than you initially wanted or expected to, in order to attract the right candidate?

57% report that they have paid a higher salary than they had expected to when recruiting IT staff in the last 12 months. This is an increase from 45% last year.

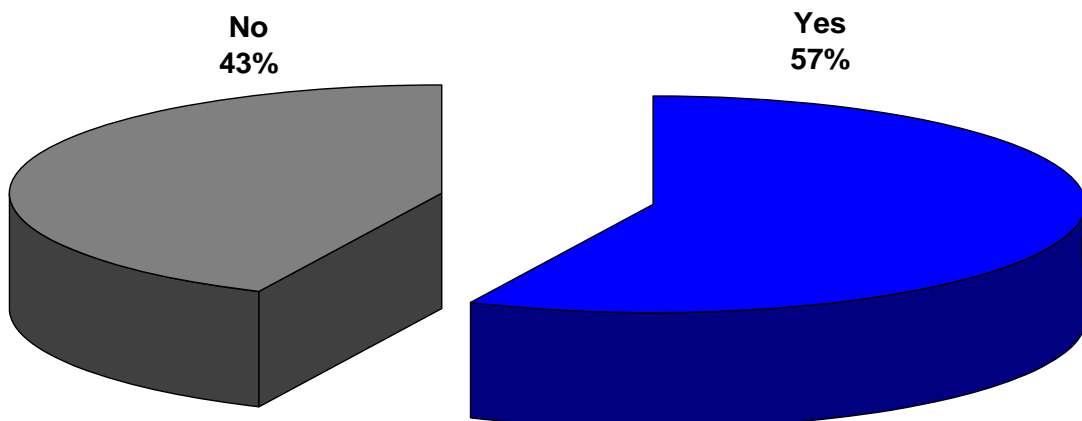

5. Recruitment Strategies: 'Buy or Build?'

Over 60% of respondents follow the 'build' hiring strategy (find and hire the right attitude/behaviours and be prepared to train on the skills). Figure 5.1 clearly shows the swing in this direction of the last 3 years.

5.1 Which statement most closely reflects your approach to recruitment? (Comparison 2006/2007/2008)

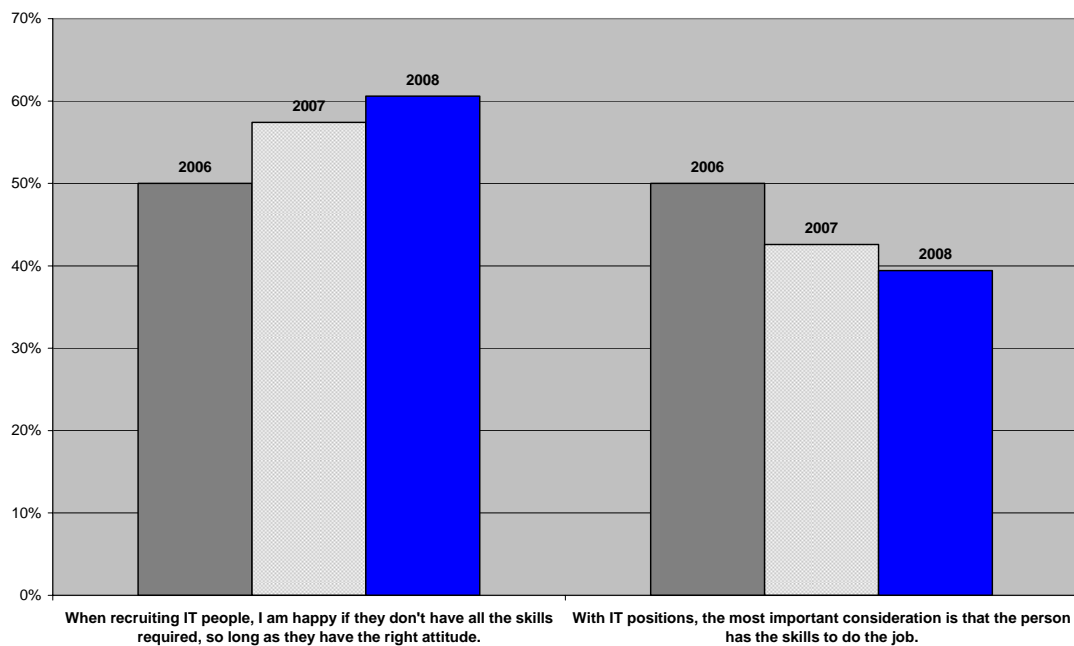

Consistent with this, there has been a sharp increase in the amount of IT graduate recruitment. The number of respondents with an IT graduate programme has increased from 20% to 32%. Those that hired graduates in the last 12 months increased from 27% to 37%. However, it is interesting that whilst over 60% adhere to 'build' strategies, only 37% have hired graduates.

Some commented on the lower availability of IT graduates, as well as declining student standards, as factors putting a brake on their build strategies.

(See next page for supporting diagrams)

5.2 Do you have a graduate recruitment program for IT staff?

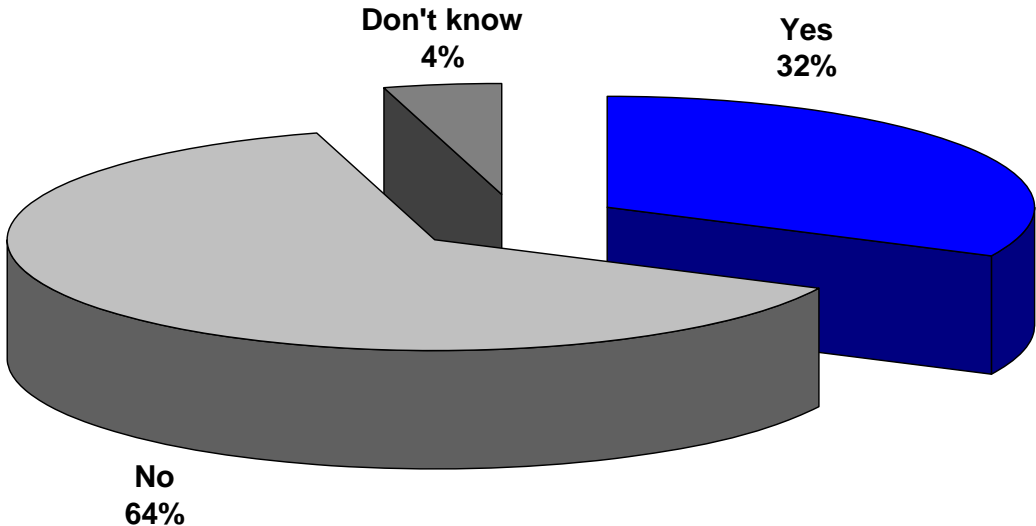

5.3 Have you hired IT graduates in the last 12 months?

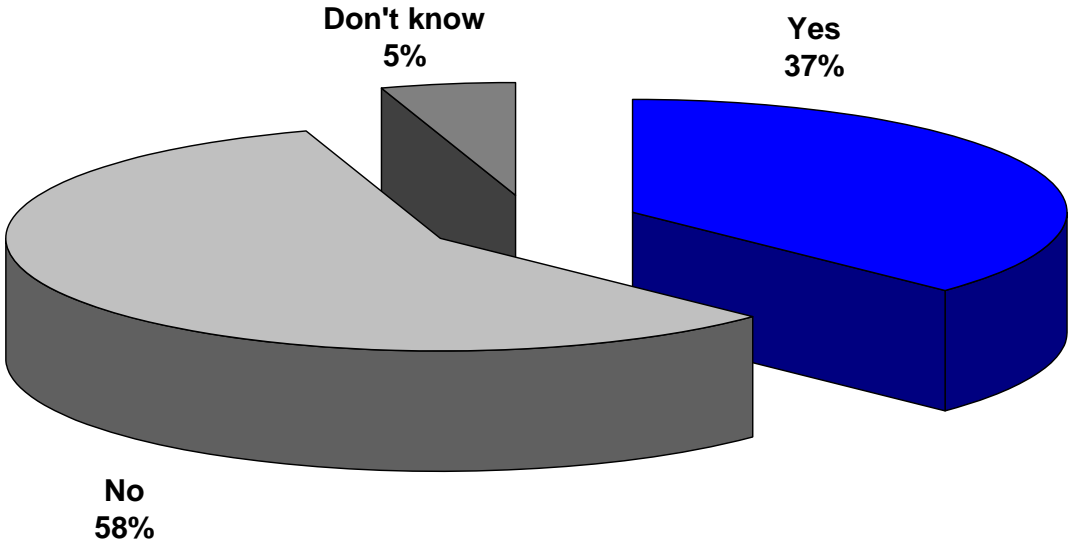

5.5 Is your organisation a standard business sponsor of IT workers on subclass 457 visas?

Interestingly, only 7% of respondents knew of their ability to hire IT workers on a 457 visa. Unsurprisingly, of those that could, 70% did. With changes in the legislation that currently make it more difficult for recruitment agencies to sponsor and on-hire workers to a client, this would seem to be a significant opportunity for organisations. However there appears to be great reluctance to do so with 83% of those who have not previously sponsored an IT worker responding that it is not something they would consider in the next year.

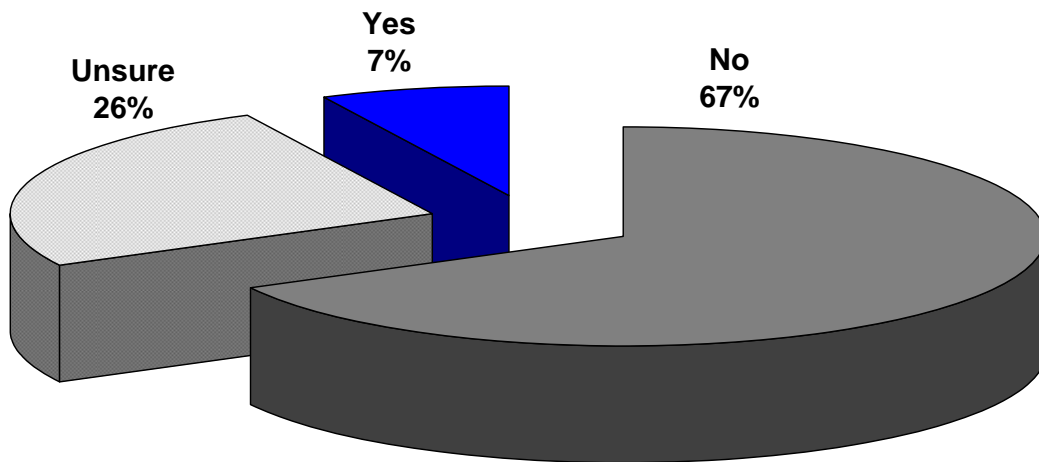

5.6 If Yes; have you sponsored an IT worker in the last 12 months?

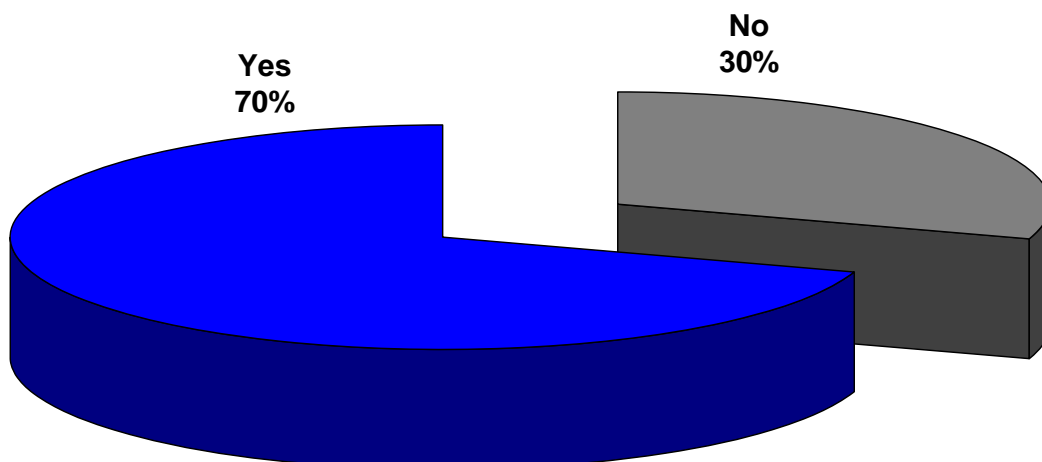

5.7 If No/Unsure; would you consider sponsoring an IT worker on a 457 visa in the next 12 months?

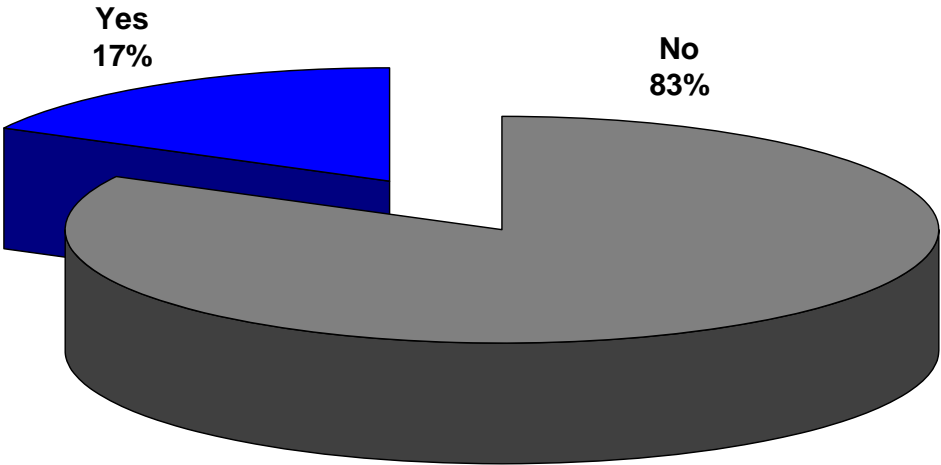

6. Hot Spots – Who’s in Demand?

The perceived difficulty of recruiting certain roles increased in the last 12 months for Management roles, Business Analysts and Infrastructure Support staff. Respondents are forecasting stronger demand for all but two of our categories (Sales and Information Management), with the strongest anticipated increases in demand being for Business Analysts and Infrastructure Development.

6.1 Which IT roles are most difficult to recruit? Comparison of 2007 respondents’ forecast against what was actually experienced by 2008 respondents in the last 12 months

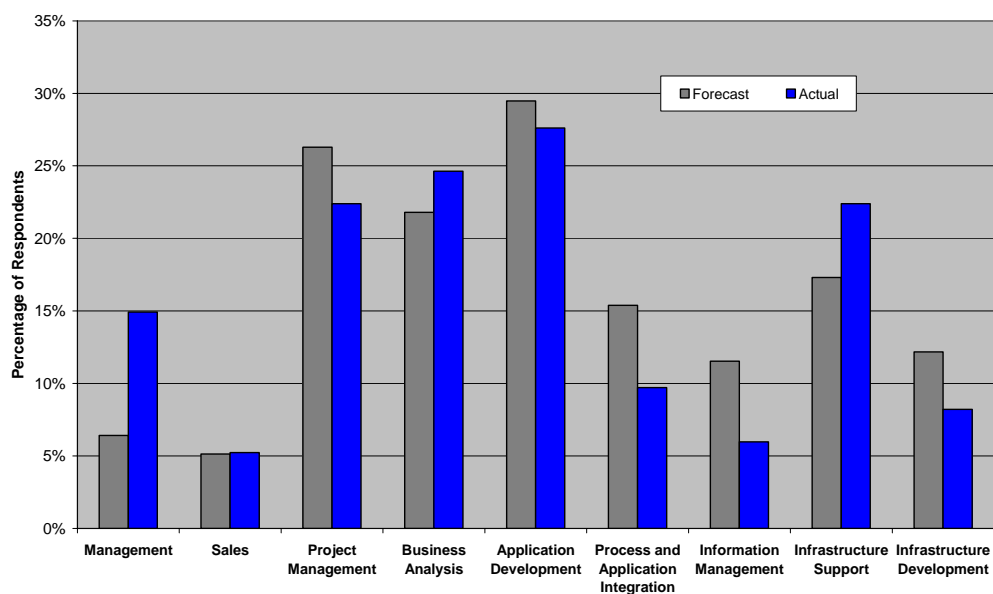

6.2 Forecasting demand for your organisation over the next 12 months, which IT role type do you expect to be in greatest demand?

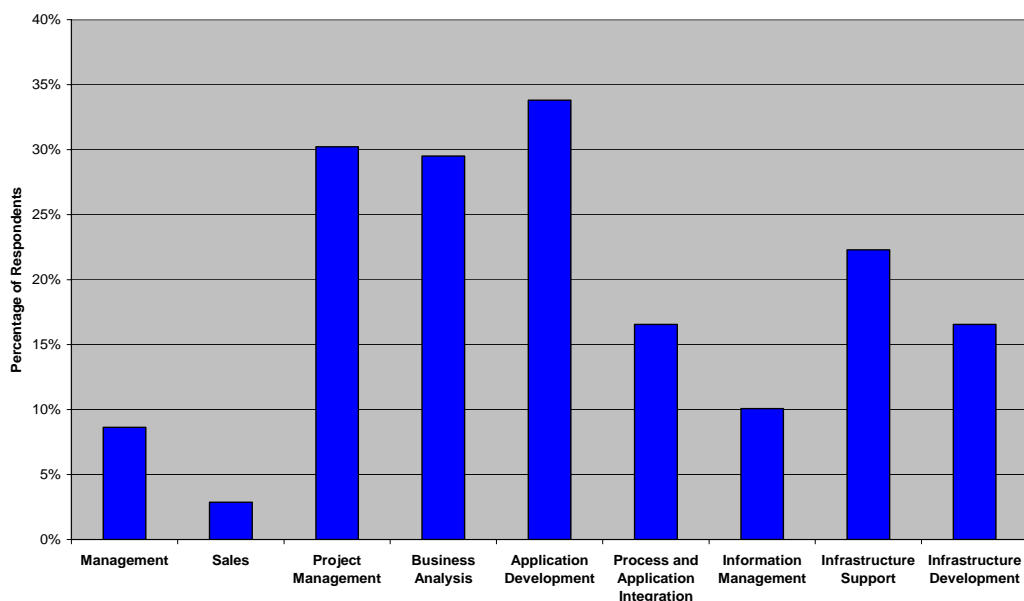

7. 'Revolving Doors'

Staff turnover levels have increased in the last 12 months. The number of respondents indicating staff turnovers of more than 15% has increased from 11% to 20%. Figure 7.2 shows that all sectors have experienced higher levels of staff turnover.

7.1 What has been the approximate % rate of your IT staff turnover over the last 12 months?

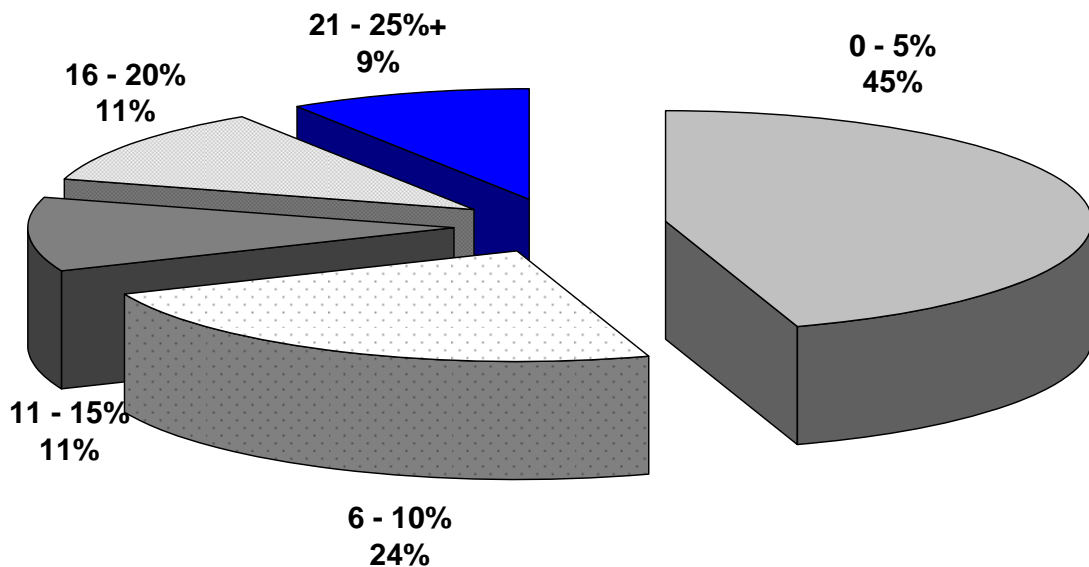

7.2 What has been the approximate % rate of your IT staff turnover over the last 12 months? (Comparison 2004/05/06/07/08)

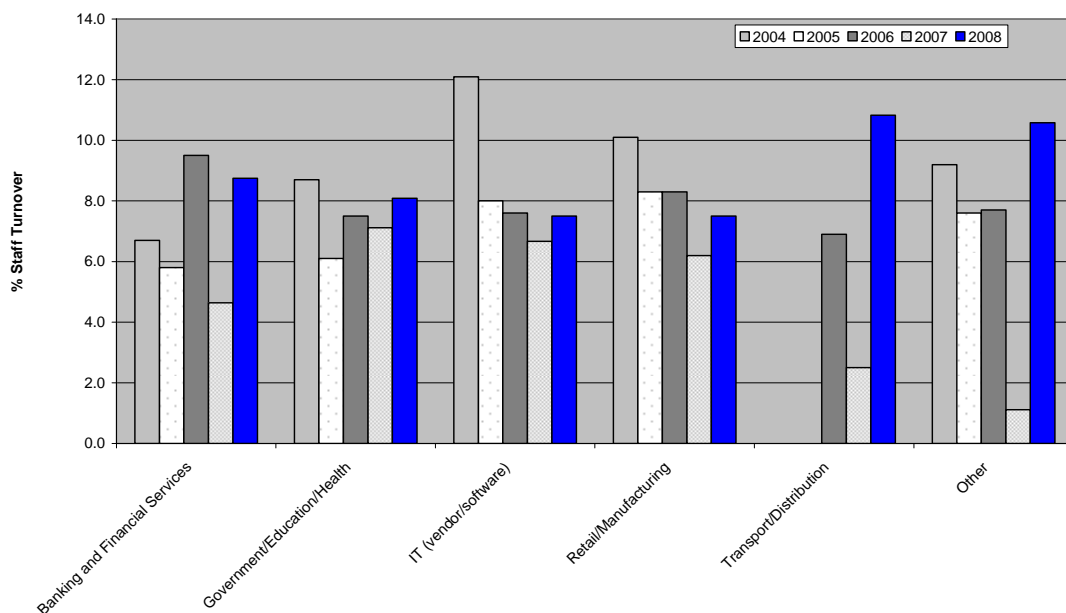

7.3 Of the people who left in the last 12 months, what % was involuntary and what % was voluntary?

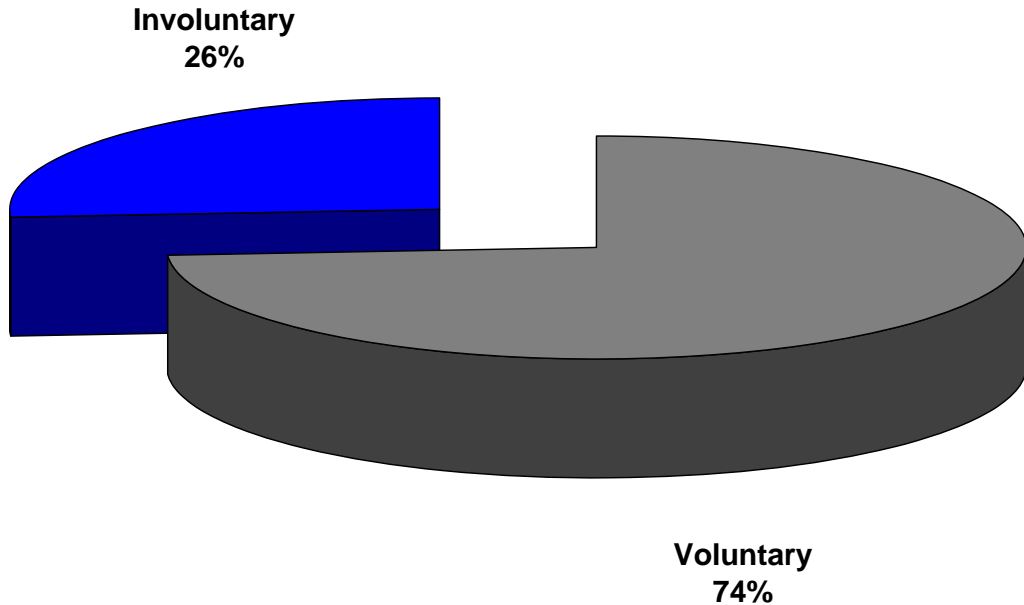

7.4 Which of these special initiatives does your organisation provide to improve your staff retention? (Comparison 2006/2007/2008)

At a time when it is clear from the data that respondents want to train (Figure 5.1) and retain (Figure 4.2) it seems inconsistent that use of other retention strategies as outlined in the figure below has generally fallen.

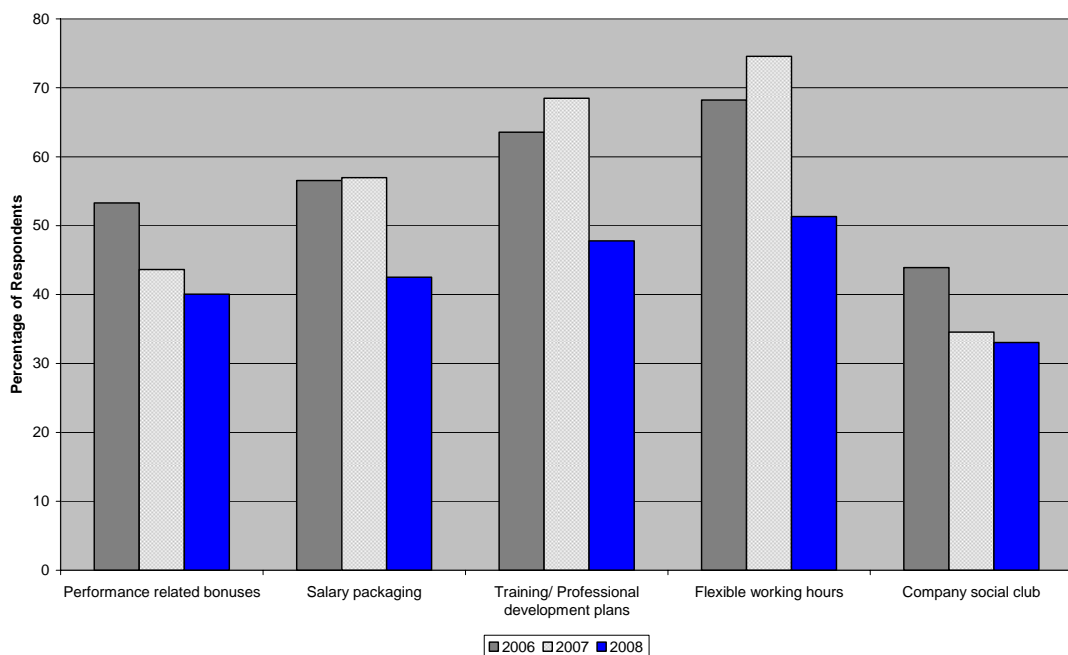

7.5 In the last 12 months, have you had employment offers to candidates rejected?

48% of respondents have experienced their offer of employment being rejected by the candidate compared with 44% 12 months ago, and 60% indicated this to be for financial reasons (compared with 48%)

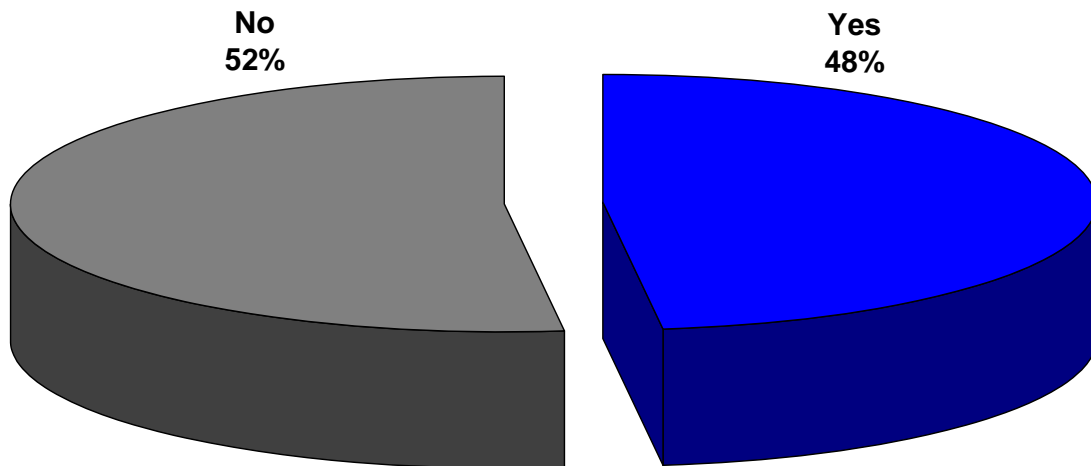

7.6 If Yes, what has been the main reason for this?

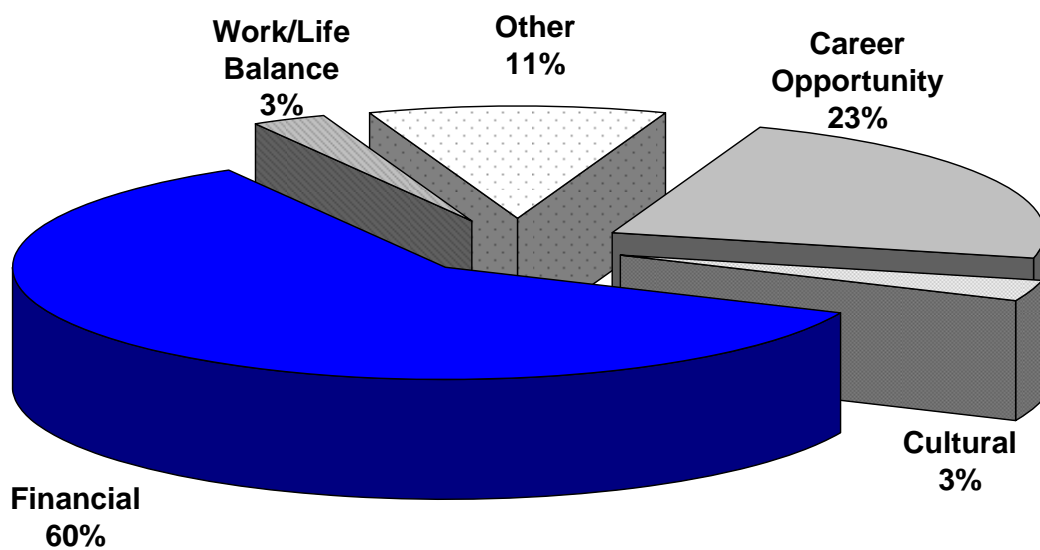

8. 'The Daily Grind'

Overall our respondents are working more hours. Twelve months ago 38% were working more than 40 hours, increasing to 44% this year. Some weekend work is experienced by 96% of respondents, compared with 94% 12 months ago.

With IT being, in many cases, a 24/7 support function to business, the expectations of working conditions for IT workers are changing. Demand for high availability of business systems means maintenance work needs to be completed outside of core business hours; rosters and shift work; and people 'doing what they have to do to get the job done' are all causes for this increase.

8.1 How many hours do you expect your IT staff to work per week on average?

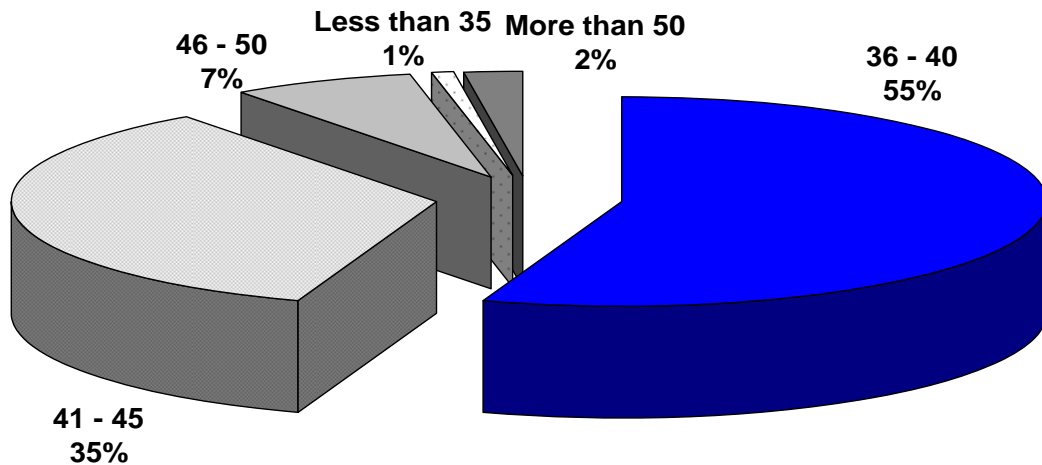

8.2 In a typical year, how many times would you require IT staff to work during a weekend?

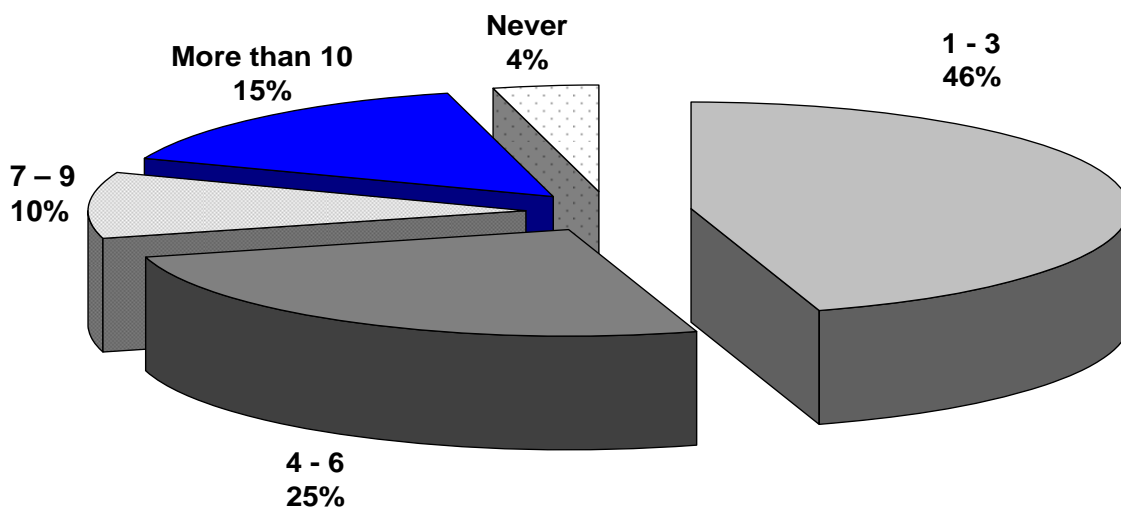

9. Barbeque Test

9.1 When you tell people that you work in IT, how do they react? (Comparison 2006/2007/2008)

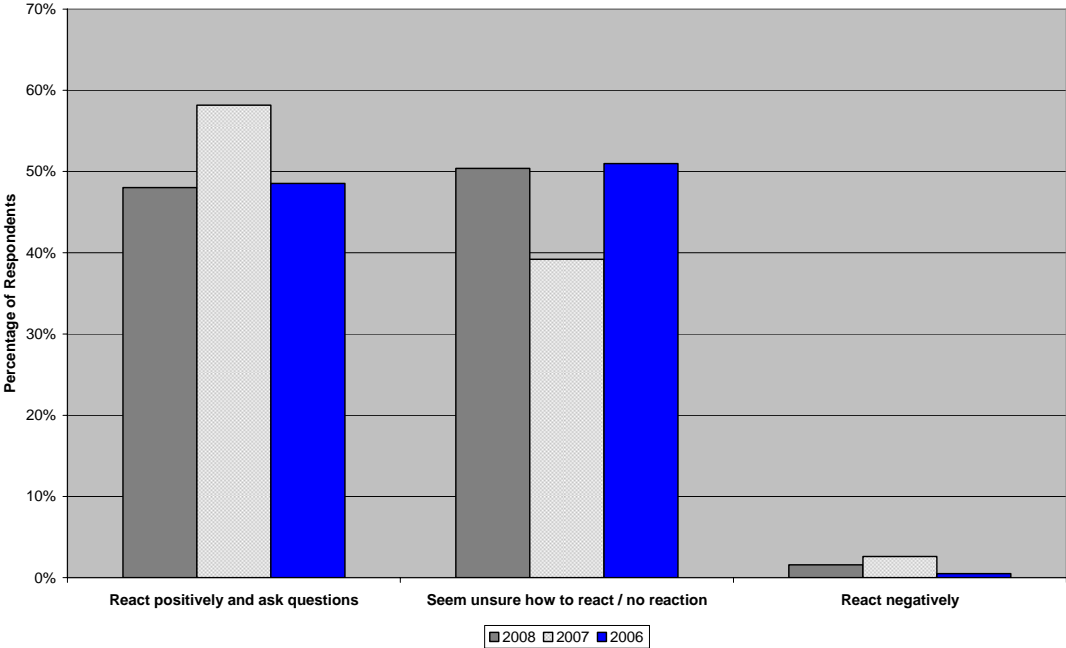

10. IT Health Check

In order to assess the health of the IT industry, we asked respondents to indicate how strongly they agree or disagree with the following 5 statements, where a rating of 0 was strongly disagree and 5 was strongly agree:

- We can see that for the next 3 years demand for IT services and products will remain strong
- IT is meeting business demands and driving business improvement
- IT budgets are increasing as a % of company revenue
- The supply of IT talent is aligned to the demand for it
- The industry has a reputation for delivering value and results, on time and on budget

Converting the responses to a percentage, where 100% would mean a totally healthy industry and 0% would be totally unhealthy, our health rating for the IT industry has fallen slightly.

10.1 IT Industry Health Rating

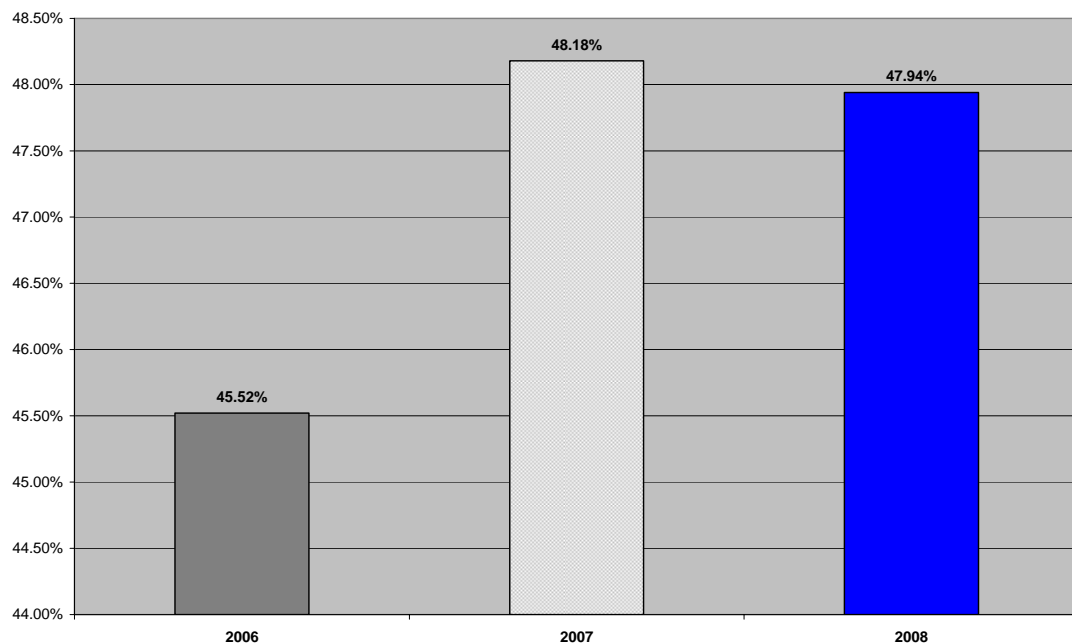

About our sample

Survey respondents by Industry Sector

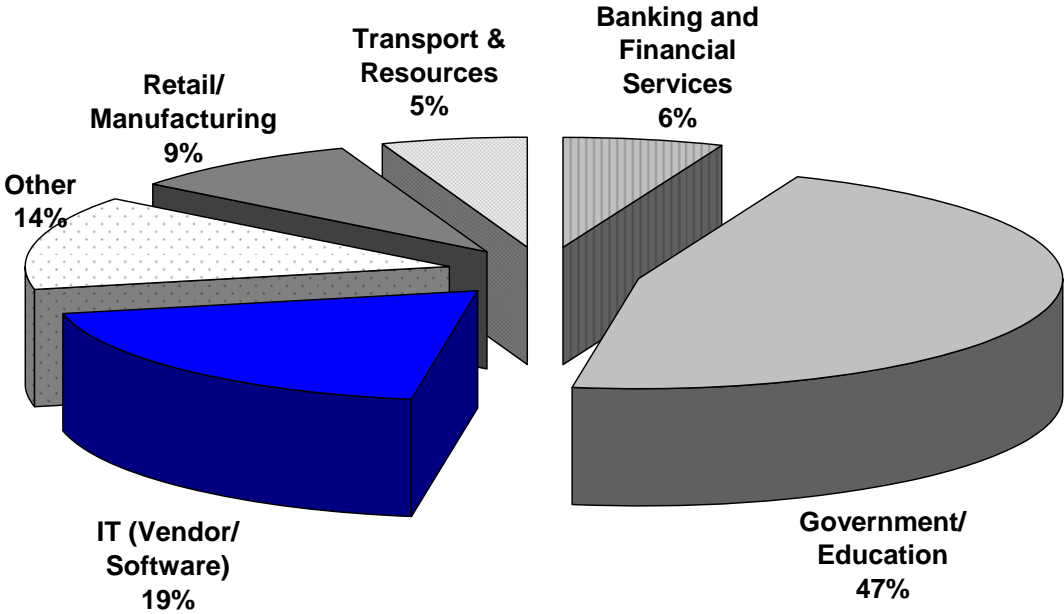

Survey respondents by Company Size (total employee numbers)

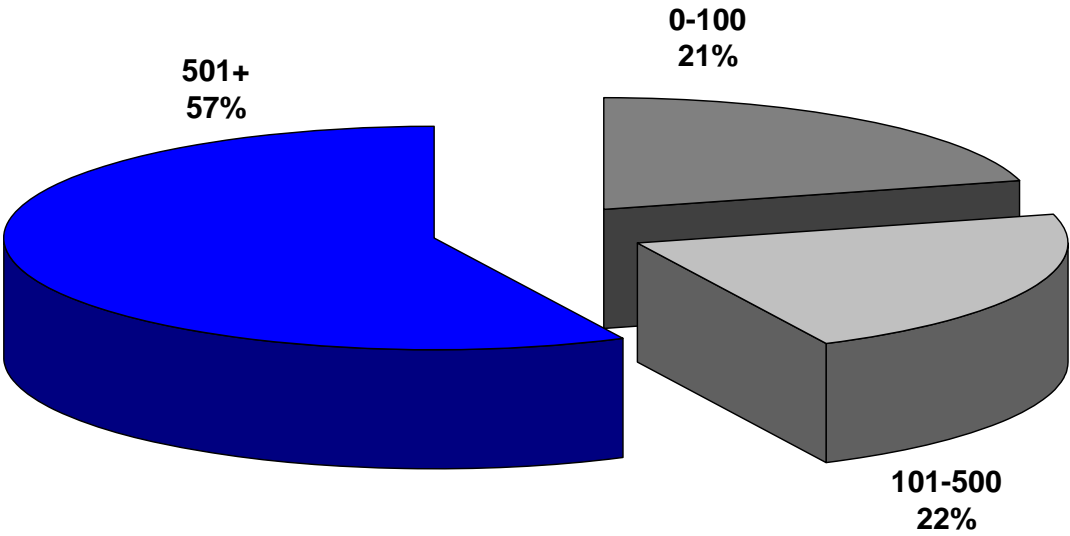

CLICKS

I.T. Recruitment

Melbourne

Level 21, 303 Collins Street, Melbourne Vic 3000

T: 03 9963 4888

E: vic@clicksrecruit.com.au

Sydney

Level 11, 39 York Street, sydney NSW 2000

T: 02 9200 4444

E: nsw@clicksrecruit.com.au

Canberra

Level 8, 15 London Circuit, Canberra ACT 2600

T: 02 6202 7700

E: act@clicksrecruit.com.au

beddison
A BEDDISON GROUP COMPANY